

SERVICE INSTRUCTION

INSPECTION AND LUBRICATION OF WASTEGATE

FOR ROTAX® ENGINE TYPE 914 (SERIES)

SI-914-003 R1

Repeating symbols:

Please, pay attention to the following symbols throughout this document emphasizing particular information.

- ▲ **WARNING:** Identifies an instruction, which if not followed, may cause serious injury or even death.
- **CAUTION:** Denotes an instruction which if not followed, may severely damage the engine or could lead to suspension of warranty.
- ◆ **NOTE:** Information useful for better handling.

1) Planning information

1.1) Engines affected

All versions of the engine type:

- 914 F all
- 914 UL all
- V914 pre-production

1.2) Concurrent ASB/SB/SI and SL

none

1.3) Reason

Due to use of leaded gas (AVGAS) under certain conditions deposits can build upon the wastegate-shaft and bearing. As a consequence the wastegate will operate in a sluggish way and may even get stuck.

1.4) Subject

Inspection and lubrication of wastegate for ROTAX® Engine Type 914 (Series).

1.5) Compliance

NONE - For Information Only

1.6) Approval

The technical content is approved under the authority of DOA No. EASA.21J.048.

1.7) Manpower

Estimated man-hours:

engine installed in the aircraft - - - manpower time will depend on installation and therefore no estimate is available from the engine manufacturer.

1.8) Mass data

change of weight - - - none.

moment of inertia - - - unaffected.

1.9) Electrical load data

no change

1.10) Software accomplishment summary

no change

1.11) References

In addition to this technical information refer to current issue of

- Operators Manual (OM)
- Maintenance Manual (MM)

◆ NOTE: The status of Manuals can be determined by checking the table of amendments of the Manual. The 1st column of this table is the revision status. Compare this number to that listed on the ROTAX® WebSite: www.rotax-aircraft-engines.com. Updates and current revisions can be downloaded for free.

1.12) Other publications affected

none

1.13) Interchangeability of parts

not affected

2) Material Information

2.1) Material - cost and availability

Price and availability will be supplied on request by ROTAX® Authorized Distributors or their Service Center.

2.2) Company support information

none

2.3) Material requirement per engine

none

2.4) Rework of parts

none

2.5) Special tooling/lubricant-/adhesives-/sealing compound

Price and availability will be supplied on request by ROTAX® Authorized Distributors or their Service Centers.

Fig.no.	New p/n	Qty/engine	Description	Old p/n	Application
		as required	MoS ₂ -Spray*	-	wastegate-bearing
		as required	LOCTITE ANTI SEIZE 8151	297434	wastegate-bearing

* or equivalent

■ CAUTION: In using these special tools observe the manufacturers specifications.

3) Accomplishment / Instructions

Accomplishment

All the measures must be taken and confirmed by the following persons or facilities:

- ROTAX® -Airworthiness representative
- ROTAX® -Distributors or their Service Centers
- Persons approved by the respective Aviation Authority

▲ **WARNING:** Proceed with this work only in a non-smoking area and not close to sparks or open flames. Switch off ignition and secure engine against unintentional operation. Secure aircraft against unauthorized operation.

▲ **WARNING:** Risk of scalds and burns! Allow engine to cool sufficiently and use appropriate safety gear while performing work.

▲ **WARNING:** Should removal of a locking device (e.g. lock tabs, self-locking fasteners, etc.) be required when undergoing disassembly/assembly, always replace with a new one.

◆ **NOTE:** All work has to be performed in accordance with the relevant Maintenance Manual.

3.1) Instructions

(see fig. 1)

▲ **WARNING:** Always allow the engine to cool down to ambient temperature before starting work. Otherwise you risk getting severely burned or scalded!

3.1.1) Checking of wastegate for free movement and verification of the turbo charger

1. Activate master switch to power up TCU.
2. Verify complete sequence of self-test.
3. Observe wastegate should move from the closed position to fully open and then return to the fully closed position. This movement should take about 5 seconds to complete. Verify if at self-test the positions „wastegate open“ and „wastegate closed“ will be reached (see fig. 1).
4. Turn off master switch.

▲ **WARNING:** If the wastegate is not moving smoothly and freely, proceed according to the following points!

3.1.2) Visual inspection of the turbocharger

▲ **WARNING:** In case of damage, a new turbo charger must be installed in accordance with the relevant Maintenance Manual. A repair of the turbo charger is not possible!

3.1.3) Removal of bowden cable

1. Disconnect negative terminal from battery.
2. Remove the bowden cable from the wastegate control arm in accordance with the current Maintenance Manual of the respective engine type.
3. Manually check for smooth movement of wastegate lever.

3.1.4) Re-establishment of free motion of the wastegate

1. Apply penetrating oil or anti size (3) (i.e.: MoS₂-Spray, Mouse-Milk or equivalent products) onto the wastegate bearing (1, 2).
 - ◆ **NOTE:** Removal of the muffler may be required to adequately apply the lubricant to the shaft/bearing area.
2. Commencing with engine S/N 4,419.669 and from 4,420.695 the bearing bushing as an additional lubrication bore. This lubrication bore is suitable to apply penetrating oil onto the bearing bushing. In this case removal of the muffler is not necessary.
 - ◆ **NOTE:** A spray nozzle with a tube (4) should be used to apply the penetrating oil.
3. Turn wastegate lever several times and apply penetrating oil onto the wastegate bearing (1, 2) until it operates smoothly.

4. If the approach given above does not result in a smooth operating wastegate replacement of the turbo is necessary. A repair of the turbocharger is not possible.
5. Install the exhaust system in accordance with the current Maintenance Manual of the respective engine type. Installation of bowden cable.

3.1.5) Installation of bowden cable

1. The bowden cable has to be installed in accordance with the current Maintenance Manual of the respective engine type.

3.1.6) Adjustment of the Bowden cable and check of the wastegate

1. The bowden cable has to be adjusted in accordance with the current 912/914 Heavy Maintenance Manual.
2. „Check of the wastegate“ in accordance with the current 914 Line Maintenance Manual.
 - Restore aircraft to original operating configuration.
 - Connect negative terminal of aircraft battery.

3.2) Test Run

Conduct test run of engine including ignition check and leakage test.

3.3) Summary

These instructions (section 3) have to be conducted in accordance with compliance in section 1.5.

Approval of translation to best knowledge and judgement - in any case the original text in German and the metric units (SI-system) are authoritative.

4) Appendix

the following drawings should convey additional information:

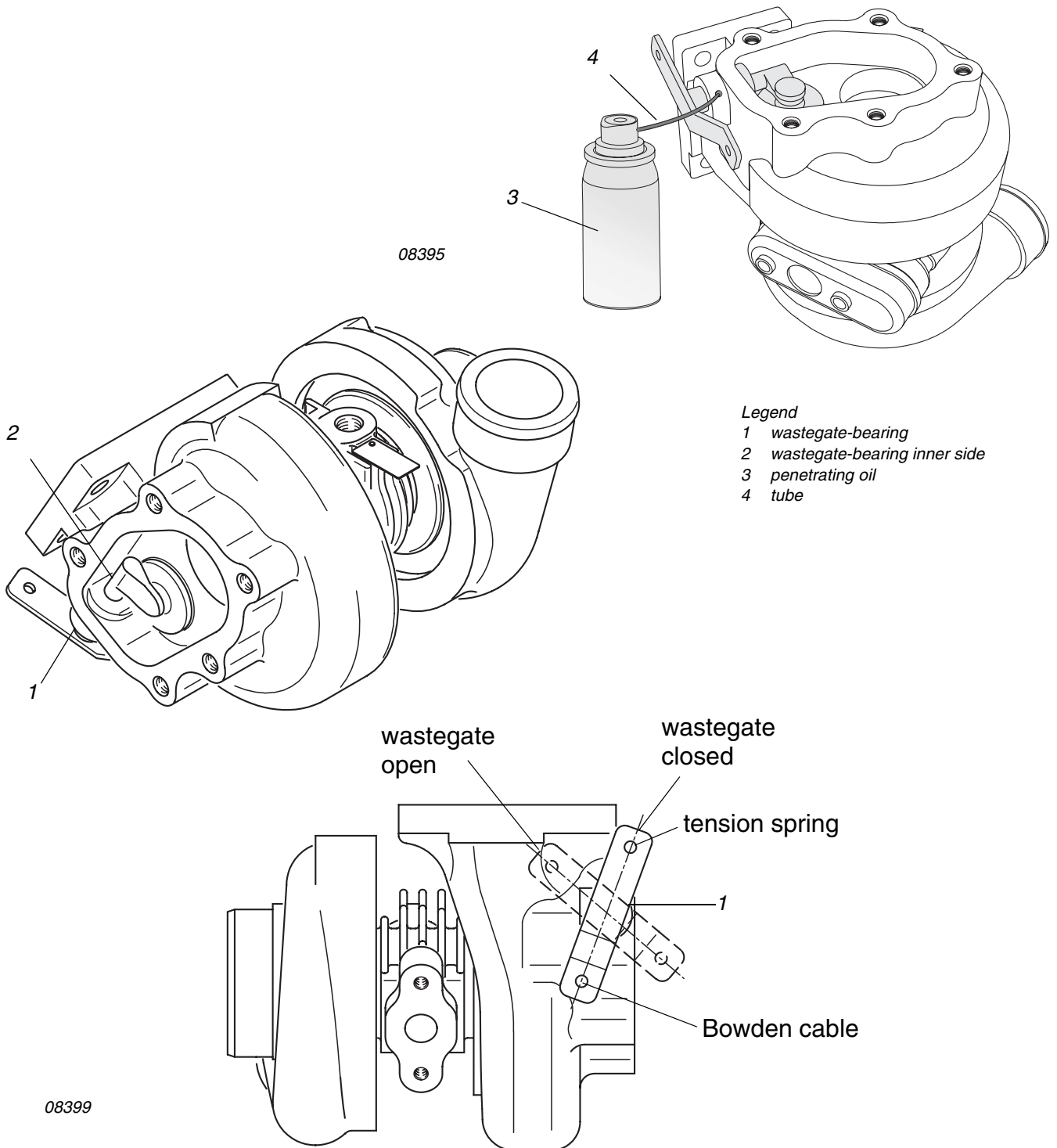

Legend

- 1 wastegate-bearing
- 2 wastegate-bearing inner side
- 3 penetrating oil
- 4 tube

Fig. 1

Lubrication of the Wastegate-Bearing

- ◆ **NOTE:** The illustrations in this document show the typical construction. They may not represent full detail or the exact shape of the parts which have the same or similar function. Exploded views are **no technical** drawings and are for reference only. For specific detail, refer to the current documents of the respective engine type.