



## SERVICE INSTRUCTION

# Introduction of new oil radiator/-sets on ROTAX® Engine Type 912 i, 912 and 914 (Series)

ATA System: 79-00-00 Lubrication system

**OPTIONAL**

### 1) Planning information

To obtain satisfactory results, procedures specified in this publication must be accomplished with accepted methods and prevailing legal regulations.

BRP-Powertrain GmbH & Co KG. cannot accept any responsibility for the quality of work performed in accomplishing the requirements of this publication.

#### 1.1) Applicability

- All engines, which will be equipped with the new oil radiator part no. 886000/886002/886004 in the future.
- All engines of type 912/914 Series and 912 i Series equipped with:

Oil radiator set	
part no. 886032	part no. 886033
part no. 886034	part no. 886036
or Oil radiator	
part no. 886022	part no. 886023
part no. 886024	

on which the oil radiator should be replaced in course of a repair / an overhaul (if damaged or if dirty oil system etc.).

#### 1.2) Concurrent ASB/SB/SI and SL

None.

#### 1.3) Reason

In the course of continuous development and standardization new oil radiators (part no. 886000/886002/886004) have been introduced.

In comparison with the current oil radiators (part no. 886022/886023/886024) the following changes were necessary:

- Modifications in the dimensions of the oil radiator
- Increase of the number of radiator fins

#### 1.4) Subject

Introduction of new oil radiator/-sets on ROTAX® Engine Type 912 i, 912 and 914 (Series).

d06198.fm

# SERVICE INSTRUCTION

---

## 1.5) Compliance

NONE - For Information Only



Non-compliance with these instructions could result in engine damages, personal injuries or death!

## 1.6) Approval

The technical content of this document is approved under the authority of DOA ref. EASA.21J.048.

## 1.7) Labor time

Estimated labor hours:

engine installed in the aircraft - - - labor time will depend on installation and therefore no estimate is available from the engine manufacturer.

## 1.8) Mass data

change of weight - - - none.

moment of inertia - - - unaffected.

## 1.9) Electrical load data

No change.

## 1.10) Software modifications

No change.

## 1.11) References

In addition to this technical information refer to current issue of

- Operators Manual (OM)
- Illustrated Parts Catalog (IPC)
- Installation Manual (IM)
- Maintenance Manual (MM)

NOTE:

The status of the Manuals can be determined by checking the table of amendments. The 1<sup>st</sup> column of this table shows the revision status. Compare this number to the one listed on the ROTAX WebSite: [www.FLYROTAX.com](http://www.FLYROTAX.com). Updates and current revisions can be downloaded for free.

## 1.12) Other Publications affected

None.

## 1.13) Interchangeability of parts

- All replacement parts within the same size are interchangeable without limitation with the current equivalent part of the same size. See also the requirements for installation and maintenance in chapter 3.1 and 3.2.

## 2) Material Information

### 2.1) Material- cost and availability

Price and availability will be provided on request by ROTAX® Authorized Distributors or their Independent Service Centers.

### 2.2) Company support information

None.

## SERVICE INSTRUCTION

### 2.3) Material requirement per engine

None.

### 2.4) Material requirement per spare part

parts requirement:

New p/n	Qty/ engine	Description	Old p/n	Application
886000	1	Oil radiator	886022	"small"
886002	1	Oil radiator	886023	"medium"
886004	1	Oil radiator	886024	"large"
886032	1	Oil radiator set	886032	metric connections
consist of:				
886000	1	Oil radiator	886022	
242879	4	Hex nut M22x1.5	242879	Oil radiator
230387	2	Gasket ring 14.2/18/2	230387	Oil radiator
840461	2	Nipple 13.2/9.5	840461	Oil radiator
886033	1	Oil radiator set	886033	metric connections
consist of:				
886002	1	Oil radiator	886023	
242879	4	Hex nut M22x1.5	242879	Oil radiator
230387	2	Gasket ring 14.2/18/2	230387	Oil radiator
840461	2	Nipple 13.2/9.5	840461	Oil radiator
886034	1	Oil radiator set	886034	metric connections
consist of:				
886004	1	Oil radiator	886024	
242879	4	Hex nut M22x1.5	242879	Oil radiator
230387	2	Gasket ring 14.2/18/2	230387	Oil radiator
840461	2	Nipple 13.2/9.5	840461	Oil radiator
886036	1	Oil radiator set	886036	UNF connections
consist of:				
886004	1	Oil radiator	886024	
242879	4	Hex nut M22x1.5	242879	Oil radiator
230387	2	Gasket ring 14.2/18/2	230387	Oil radiator
956643	2	Adapter 3/4-16 UNF/M14x1.5	956643	Oil radiator

d06198.fm

## SERVICE INSTRUCTION

### 2.5) Rework of parts

None.

### 2.6) Special tooling/lubricant-/adhesives-/sealing compound/price and availability

None.

## 3) Accomplishment/Instructions

**NOTE:** Before accomplishment, review the entire documentation to make sure you have a complete understanding of the procedure and requirements.

### Accomplishment

All measures must be implemented and confirmed by at least one of the following persons or organizations:

- ROTAX® - Airworthiness representatives
- ROTAX® - Distributors or their Service Centers
- Persons approved by the respective Aviation Authority
- Persons with approved qualifications for the corresponding engine types. Only authorized persons (iRMT, Level Heavy Maintenance) are entitled to carry out this work.

**NOTE:** All work has to be performed in accordance with the relevant Maintenance Manual.

- Secure aircraft against unauthorized operation
- Disconnect negative terminal of aircraft battery

### Safety notice



**WARNING**

Identifies an instruction which, if not followed, may cause serious injury or even fatal injury.



**CAUTION**

Identifies an instruction which, if not followed, may cause minor or moderate injury.

**NOTICE**

Identifies an instruction which if not followed, may severely damage the engine or could lead to suspension of warranty.

### **ENVIRONMENTAL NOTE**

Environmental notes give you tips on environmental protection.

# SERVICE INSTRUCTION

## 3.1) Requirements for installation

Pay attention to the specifications of the latest version of the Installation Manual for the corresponding engine type.

For the installation observe the following relevant changes:

- see modified outer dimensions as shown in [Fig. 2](#).

### NOTICE

Any changes to oil radiator are not permissible.  
See [Fig. 2](#).

- see different position of the fins.

## 3.2) Requirements for maintenance

During the visual inspection of the oil radiator also make sure that the exterior contours or channels do not have damages or oil leaks.

- Restore aircraft to original operating configuration.
- Connect negative terminal of aircraft battery.

## 3.3) Test run

Conduct test run including ignition check and leakage test.

## 3.4) Summary

These instructions (section 3) have to be carried out in accordance with the deadlines specified in section 1.5.



A revision bar outside the page margin indicates a change to text or graphic.

Approval of translation to best knowledge and judgement - in any case the original text in German language and the metric units are authoritative.

## 3.5) Enquiries

Enquiries regarding this Service Instruction should be sent to the ROTAX® authorized distributor of your area.

A list of all distributors is provided on [www.FLYROTAX.com](http://www.FLYROTAX.com).

## 4) Appendix

The following drawings should provide additional information:

NOTE: The illustrations in this document show the typical construction. They may not represent full detail or the exact shape of the actual parts but the same or similar function.

Exploded views are **no technical drawings** and shall be used for reference purposes only. For specific detail, refer to the current documents of the respective engine type.

Fig.	Description
1	Oil radiator (old version)
2	Oil radiator (new version)

d06198.fm

# SERVICE INSTRUCTION

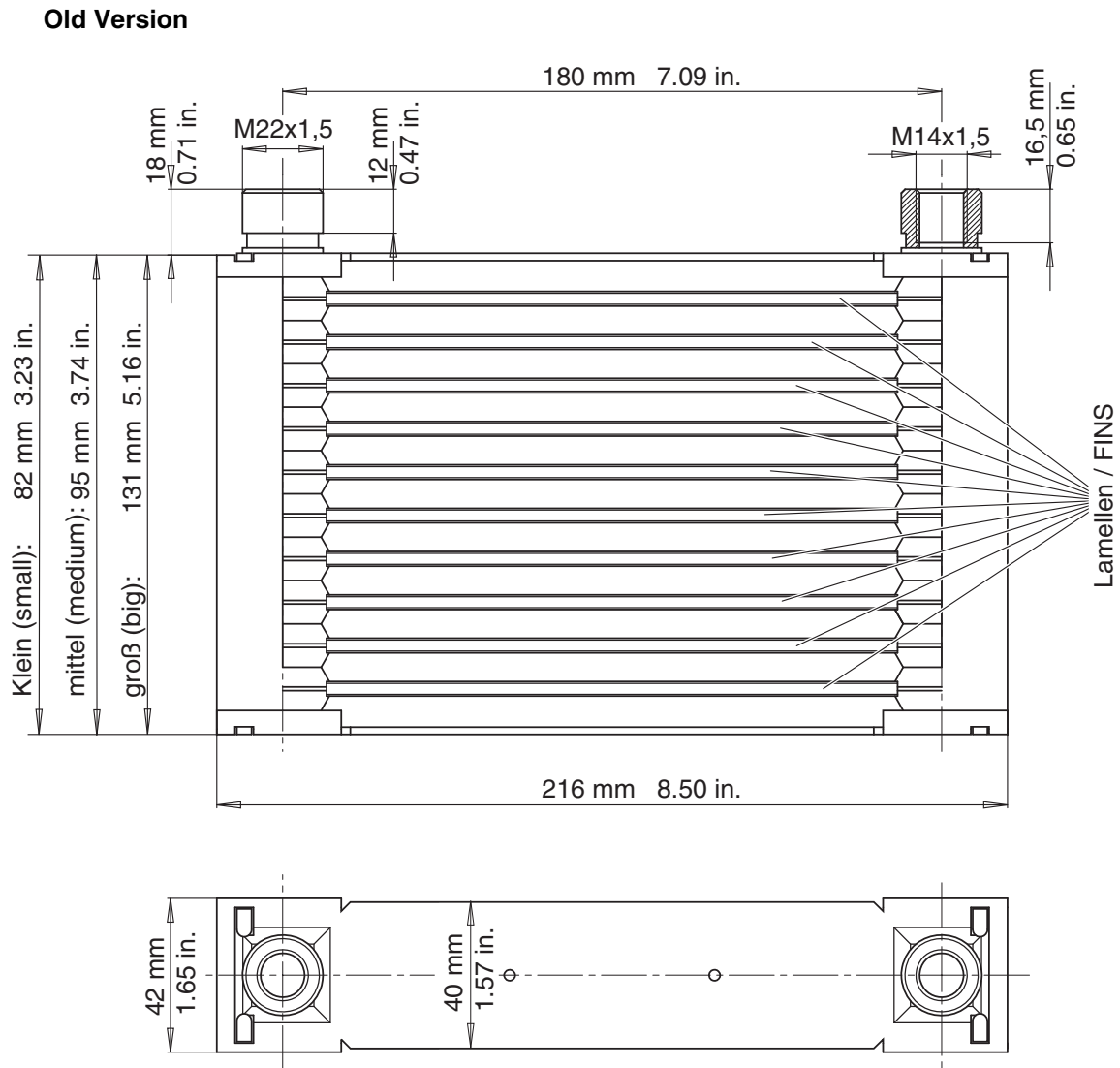

Fig. 1

10248\_a

# SERVICE INSTRUCTION

## New Version

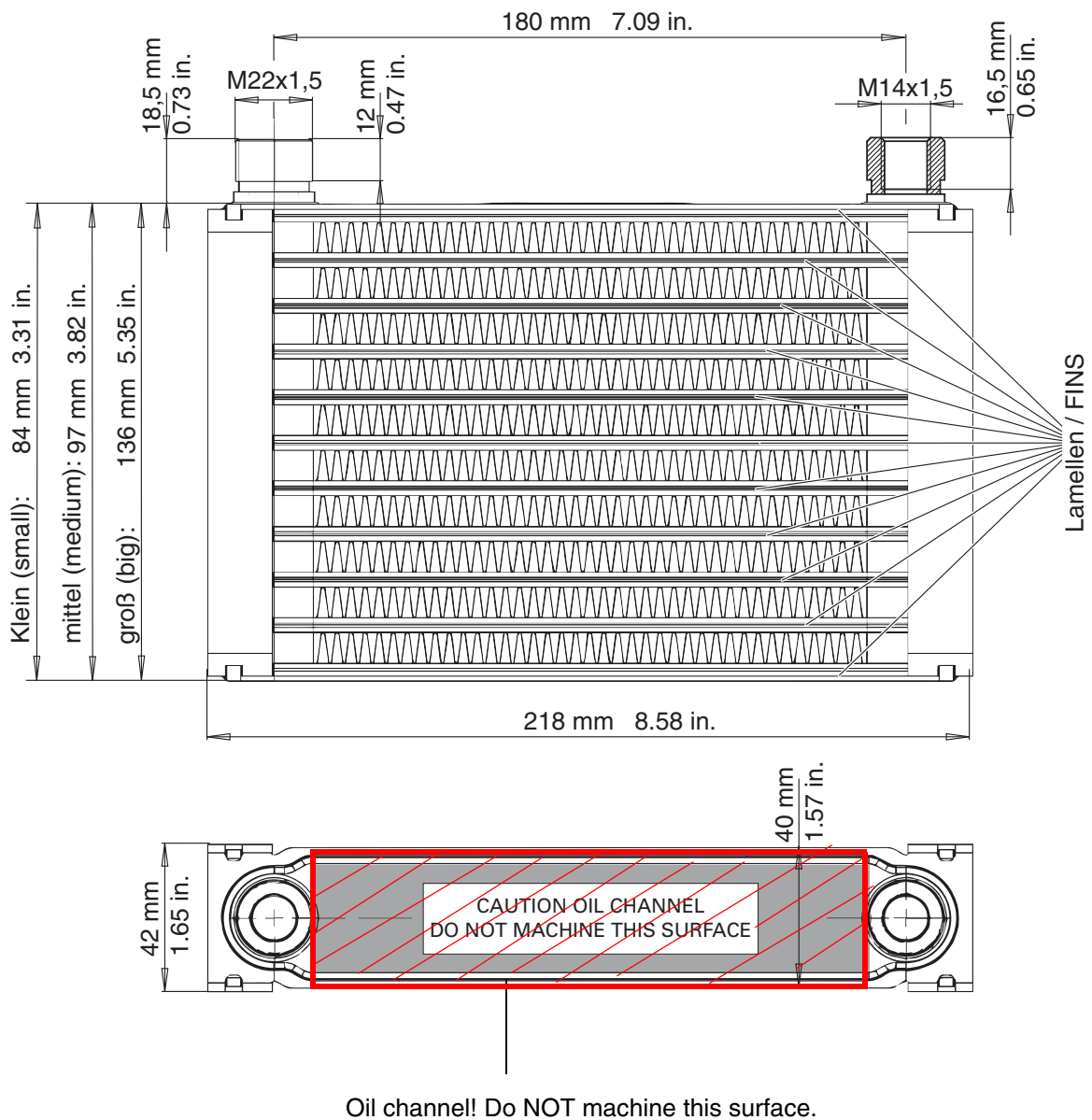

Fig. 2

10248\_b

d06198\_fm