



## SERVICE BULLETIN

# Periodic inspection of the float buoyancy for ROTAX® Engine Type 912 and 914 (Series)

ATA System: 73-00-00 Fuel system

### MANDATORY

#### Symbols used:

Please, pay attention to the following symbols throughout this document emphasizing particular information.

#### General note



Identifies an instruction which, if not followed, may cause serious injury or even fatal injury.



Identifies an instruction which, if not followed, may cause minor or moderate injury.

#### NOTICE

Denotes an instruction which if not followed, may severely damage the engine or could lead to suspension of warranty.

#### ENVIRONMENTAL NOTE

Environmental notes give you tips on environmentally conscious behaviour.

NOTE: Information useful for better handling.

A revision bar outside of the page margin indicates a change to text or graphic.

To obtain satisfactory results, procedures specified in this publication must be accomplished with accepted methods and prevailing government regulations.

BRP-Powertrain GmbH & Co KG. cannot be responsible for the quality of work performed in accomplishing the requirements of this publication.

# SERVICE BULLETIN

## 1) Planning information

### 1.1) Applicability

All engines of Series 912 A, 912 F, 912 S and 914 F are affected, if at least one of following criteria applies:

#### Criterion A) Engine Serial number:

Engine type	Serial number
912 A	from S/N 4 410 957 up to S/N 4 411 048 inclusive
912 F	from S/N 4 413 008 up to S/N 4 413 041 inclusive
912 S	from S/N 4 924 408 up to S/N 4 924 838 inclusive
914 F	from S/N 4 421 136 up to S/N 4 421 403 inclusive

#### Criterion B) Carburetors:

The part numbers and serial numbers of the carburetors:

Carburetors	Serial number
912 A/F	1/3 part no. 892500 - from S/N 116434 up to S/N 144101 inclusive 2/4 part no. 892505 - from S/N 115846 up to S/N 143886 inclusive
912 S	1/3 part no. 892530 - from S/N 121087 up to S/N 143702 inclusive 2/4 part no. 892535 - from S/N 120980 up to S/N 143505 inclusive
914 F	1/4 part no. 892520 - from S/N 116207 up to S/N 143799 inclusive 2/4 part no. 892525 - from S/N 120228 up to S/N 143310 inclusive

#### Criterion C) Spare parts:

Further all engines are affected, which have been equipped during engine repair, maintenance or general overhaul as of July 01, 2012 with floats with the part no. 861184, which have not been marked (see page 7, chapter 3.3).

NOTE: The carburetor and/or the float may have been removed from the initial engine and used on another one.

Engines and/or carburetors with serial numbers higher than in criterion A or B have already been equipped with tested floats. To provide traceability the floats were marked as described in section 3.3.

For relevant information, see the maintenance records and/or the logbook.

# SERVICE BULLETIN

---

## 1.2) Concurrent ASB/SB/SI and SL

In addition to this Service Bulletin the following Service Documents must be observed and complied with:

- Service Instruction-SI-912-021/SI-914-023, „Inspection of carburetors“, current issue.
- Service Bulletin-SB-912-067/SB-914-048, „Exchange of floats“, current issue.

## 1.3) Reason

Due to a deviation in the manufacturing process some floats could absorb more fuel thus having more weight. This leads to a loss of float buoyancy and wrong regulation of the fuel in the float chamber. Possible effects may be a rough engine running, especially at low speeds and under circumstances loss of performance and/or fuel leakage in the area of the carburetor.

## 1.4) Subject

Periodic inspection of the float buoyancy of ROTAX® engine type 912 and 914 (Series).

## 1.5) Compliance

NOTE: The installation of new floats as per SB-912-067/SB-914-048 “Exchange of floats” (latest issue) supersedes and cancels the requirement to comply with SB-912-065/SB-914-046 (latest issue).

- Before the first installation in the aircraft and/or the initial start-up.
- Carry out this inspection of float buoyancy of the engines listed in section 1.1., according to the instructions in section 3 at the next BRP maintenance event or within the next 25 hours of operation, but at the latest after 60 days (from the date of the initial issue of this Service Bulletin).
- Carry out this inspection of float buoyancy of the engines listed in section 1.1., according to the instructions in section 3 periodically after each 25 hours of operation, but at the latest after 60 days.
- At rough engine running, especially at low engine speeds (crankshaft speed to 4000 rpm), fuel odor or fuel leakage carry out this inspection before the next flight. The cause (may also be independent of the float) has to be fixed before the next flight.

NOTE: The inspection must be continued even after a replacement of the float, until new and improved floats are available. Only from this point of time the periodic inspection can be stopped. For corresponding information refer to SB-912-067/SB-914-048, latest edition.



Non-compliance with these instructions could result in engine damages, personal injuries or even fatal injury.

## SERVICE BULLETIN

---

### 1.6) Approval

The technical content of this document is approved under the authority of DOA ref. EASA.21J.048.

### 1.7) Labor time

Estimated labor time:

- engine installed in the aircraft: labor time will depend on installation and therefore no estimate is available from the engine manufacturer

### 1.8) Mass data

change of weight - - none.

moment of inertia- - - unaffected.

### 1.9) Electrical load data

no change

### 1.10) Software accomplishment summary

no change

### 1.11) References

In addition to this technical information refer to current issue of

- Maintenance Manual (MM) Heavy
- Maintenance Manual (MM) Line

NOTE: The status of manuals can be determined by checking the table of amendments of the Manual. The 1<sup>st</sup> column of this table is the revision status. Compare this number to that listed on the ROTAX<sup>®</sup> Web-Site: [www.FLYROTAX.com](http://www.FLYROTAX.com). Updates and current revisions can be downloaded for free.

### 1.12) Other Publications affected

none

### 1.13) Interchangeability of parts

- All parts are interchangeable.
- All affected parts cannot further be used and have to be returned F.O.B to ROTAX<sup>®</sup> Authorized Distributors or their Service Center.

## 2) Material Information

### 2.1) Material- cost and availability

Price, availability and any possible support will be provided on request by ROTAX<sup>®</sup> Authorized Distributors or their Service Center.

d06142.fm

## SERVICE BULLETIN

### 2.2) Company support information

NOTE: Any support from of BRP-Powertrain will be provided on request by ROTAX<sup>®</sup> Authorized Distributors or their Service Centers.

- Replaced parts must be returned F.O.B to ROTAX<sup>®</sup> Authorized Distributors or their Service Center.
- Shipping costs, downtime costs, loss of income, telephone costs etc. or costs of conversion to other engine versions or additional work, as for instance simultaneous engine overhauls, are not covered in this scope and will not be borne or reimbursed by ROTAX<sup>®</sup>.

### 2.3) Material requirement per engine

Parts requirement for checking the float buoyancy and for restoring the initial configuration:

NOTE: Use only parts indicated in the following table.

Part no.	Qty /engine	Description	Application
581385	1	Syringe	Engine type 912/914 Series
960043	1	Oil line 150 mm	
950030	2	Gasket	Choke
224045	1	Diffuser tube	

Parts requirement for replacement of the floats:

Part no.	Qty /engine	Description	Application
861184	as required	Float (pair)	Engine type 912/914 Series
830728	2	Gasket	Float chamber 912/914 Series
631771	2	O-ring 15.6x1.78	Attachment screw 914 Series

### 2.4) Material requirement per spare part

none

### 2.5) Rework of parts

none

### 2.6) Special tooling/lubricant-/adhesives-/sealing compound

none

d06142.fm

## SERVICE BULLETIN

---

### 3) Accomplishment/Instructions

**NOTE:** Before maintenance, review the entire documentation to make sure you have a complete understanding of the procedure and requirements.

#### Accomplishment

All measures must be implemented and confirmed by at least one of the following persons or organizations:

- ROTAX® - Distributors or their Service Center
- Persons with approved qualifications to the corresponding engine type. Only certified technicians (iRMT-Level: Line Maintenance) are qualified to work on these engines.

**NOTE:** All work has to be performed in accordance with the relevant Maintenance Manual.

#### Safety notice

#### **WARNING**

Proceed with this work only in a non-smoking area and not close to sparks or open flames. Switch off ignition and secure engine against unintentional operation. Secure aircraft against unauthorized operation. Disconnect negative terminal of aircraft battery.

#### **WARNING**

Risk of scalds and burns! Allow engine to cool sufficiently and use appropriate safety gear while performing work.

#### **NOTICE**

Should removal of a locking device (e.g. lock tabs, self-locking fasteners, etc.) be required when undergoing disassembly/assembly, always replace with a new one.

#### 3.1) General

Adhere to the installation instructions defined in the ROTAX® Installation Manual regarding the carburetor venting or purging and the drip tray.

#### **NOTICE**

Do not modify the floats!

# SERVICE BULLETIN

## 3.1.1) Preparation

**NOTE:** The float chamber provides a different fuel level, depending on the float buoyancy.

In the following inspection the float chamber will be filled up to the venting bore and so the required volume can be determined. The amount of fuel added indicates the resulting fuel level and provides information on the float status or buoyancy.

Step	Procedure
1	Bring the float chamber to horizontal position (level the aircraft, if necessary and check the horizontal position with a spirit level). See Fig. 1.
2	Engine Series 912: Run the engine at idle for approx. 1-2 minutes without electric fuel pump. Engine Series 914: Run the engine at idle for approx. 1-2 minutes with main fuel pump.
3	Switch off the engine and follow safety notice chap. 3.
4	Remove the return spring (1). See Fig. 2.
5	Remove 4 Philips head screws (2). Remove rotary valve housing (3) with the gasket. See Fig. 2.
6	Remove the air vent line (4). See Fig. 2.

Fig. 1

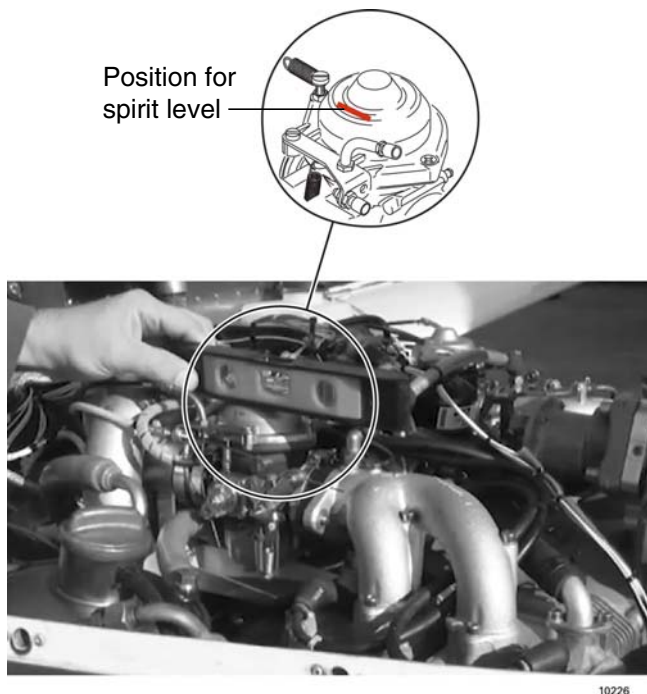

d06142.fm

## SERVICE BULLETIN

Fig. 2

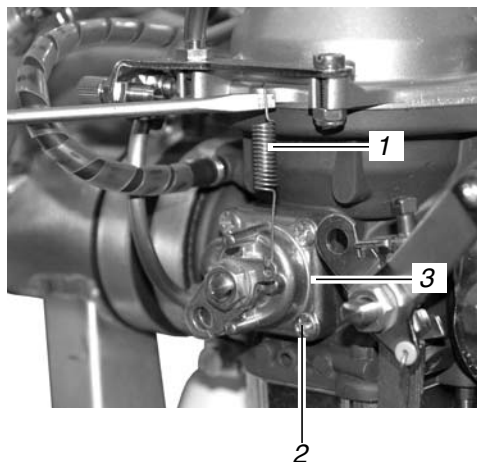

- 1 Return spring
- 2 Philips head screw M4x14
- 3 Rotary valve housing
- 4 Air vent line

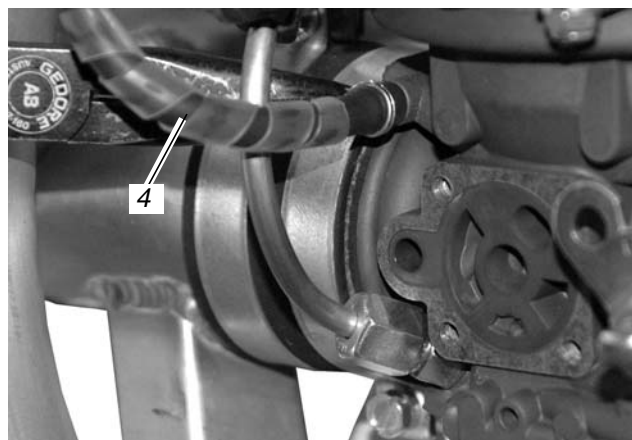

### 3.2) Inspection of float buoyancy

See Fig. 3

**NOTICE**

For inspection of the float buoyancy only use gasoline certificated by ROTAX. See latest SI-912-016/SI-914-019.

Step	Procedure
1	Fill the syringe (1) with 40-50 ml of fuel.
2	Connect syringe to the adapter (2) using a transparent fuel hose
3	Fuel hose and adapter must be free from air bubbles.
4	Insert the adapter (2) in the lower bore (3) of the carburetor housing. Ensure a firm fit.

**NOTE:**

During the following inspection of the volume, carefully fill the float chamber with a syringe until the fuel leaks from the venting nipple (4). This process should take about 5 seconds. Record capacity before the filling operation. The capacity can be determined by reading the scale of the syringe.

d06142.fm



# SERVICE BULLETIN

Fig. 3

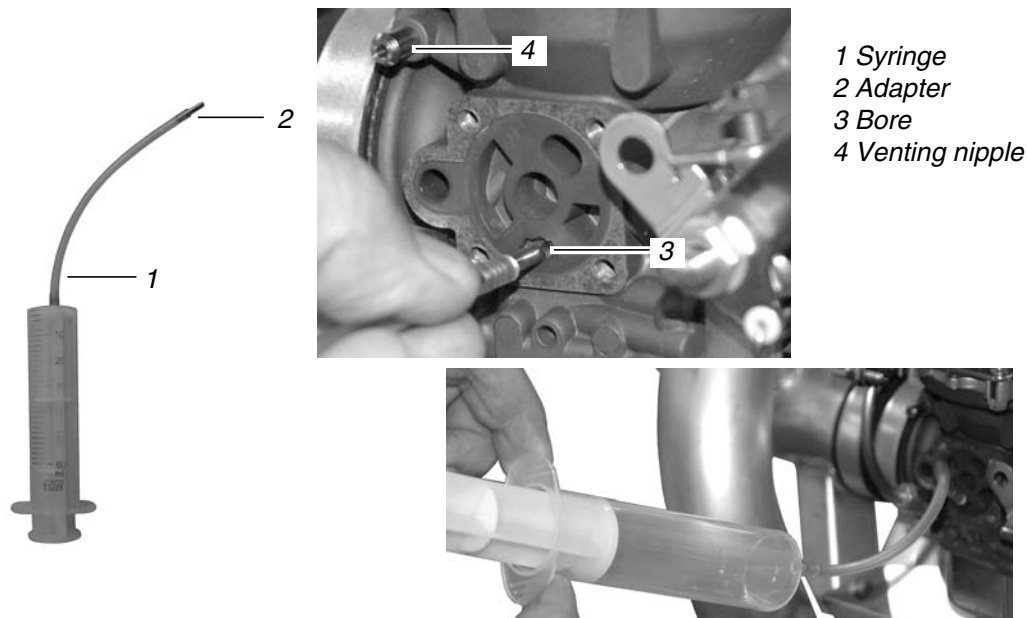

Step	Procedure
5	Fill the float chamber until the fuel leaks from the venting nipple.
6	Determine the volume.
7	Perform the same inspection on the second carburetor.
8	The results of the measurement must be documented in the maintenance records.

### 3.2.1) Determination of the filling volume

Determine the filling volume by checking the scale of the syringe.

Filling volume in float chamber	Evaluation
23 ml - 40 ml	Floats are OK, the float level is within the limit.
less than 23 ml	Significant deviation of the float levels. A detailed inspection of the floats or their weight is necessary. See section. 3.5).
more than 40 ml	Significant deviation of the float levels. Repeat inspection to avoid incorrect measurements. See section 3.1.1). A detailed inspection of the carburetor and floats or their weight is necessary. See section. 3.5). Check float needle valve for any leakage and check setting of the float bracket.

d06142.fm

# SERVICE BULLETIN

### 3.3) Installation of the choke housing

See Fig. 4.

Step	Procedure
1	Install the venting line.
2	Install rotary valve with new gasket.
3	Secure first 2 threads of the Philips head screw 4x14 (1) with LOCTITE 243.
4	Install the return spring (2).

Fig. 4

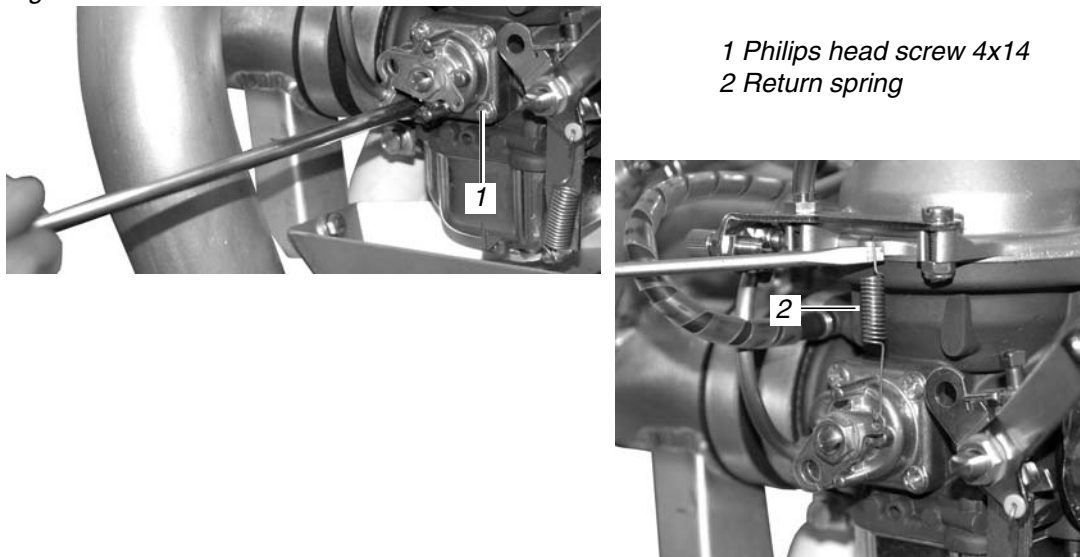

### 3.4) Removal of float chamber

See Fig. 6.

**NOTICE**

If the inspection of float buoyancy section 3.2) shows a deviation, a weight control according to section 3.5) is necessary. For this purpose, the float chamber has to be dismantled as described below.

Preparation for dismantling the float chamber according to the installation instructions of the aircraft manufacturer.

Step	Procedure
1	Remove drip tray (1).
2	Visual inspection of the carburetor and its mechanical actuation.
3	Remove spring clip (5) or for ROTAX 914 Series loosen cap screw (6) and remove with O-ring (7).
4	Remove float chamber (3), gasket (4) and the two floats (2)

d06142.fm

# SERVICE BULLETIN

## 3.5) Check of weight of the floater

10212

**NOTE:** For traceability some floats (new but also already installed) show one or two markers. The imprinting is shown in Fig. 5. These markers have no effect on the function of the floats.

Only floats without weight control markers or according to SB-912-067/ SB-914-048 have to be changed. Already marked floats (see Fig. 1) must not be changed.

The weight inspection shows whether the affected floats have absorbed fuel. This is only significant if the floats already had contact with fuel.

**NOTE:** This check is not relevant for new spare parts, that were not in contact with fuel.

Step	Procedure
1	Let the floats dry for 1-2 minutes. Only weigh dry floats.
2	Check the weight of all affected floats using a calibrated balance (1). Measuring tolerance of the balance: max. 0.1 grams.
3	The results of the measurement must be documented in the maintenance records. The max. allowable weight (of both floats together) is 7 grams.

### NOTICE

All floats which exceed the max. weight must be renewed according to the Maintenance Manual Heavy, current version.

Fig. 5



1 Marker

1022  
1022

d06142.fm

# SERVICE BULLETIN

## 3.6) Installation of float chamber

See Fig. 6.

Step	Procedure
1	Remove the gasket (4) from the float chamber and for ROTAX 914 Series exchange the O-ring (7).
2	Install float chamber (3) with gasket (4) and both floats (2).
3	Close spring clip (5) or for ROTAX 914 Series install the attachment screw (6) including O-Ring (7). Tightening torque of attachment screw 5.5 Nm (48.7 in.lb).
4	Install drip tray (1) and/or accessories according to the instructions of the aircraft manufacturer.

Fig. 6

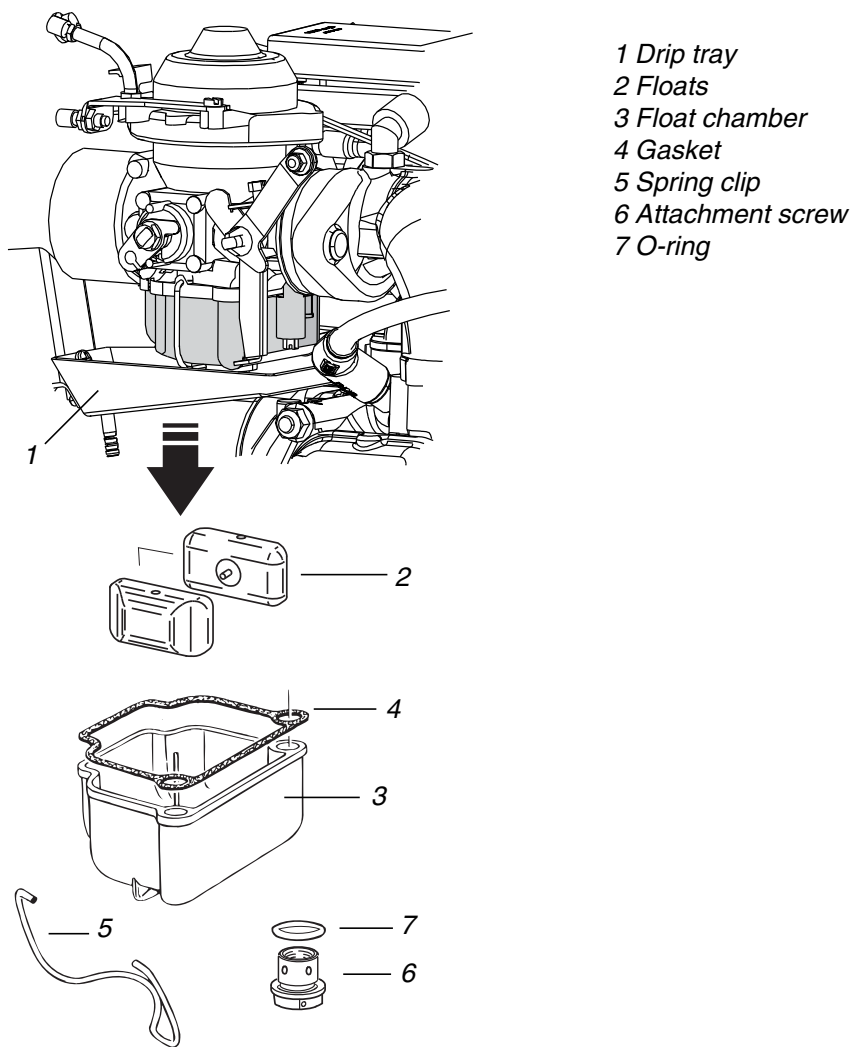

## SERVICE BULLETIN

---

### 3.7) Finishing work

- Restore aircraft to original operating configuration according to the instructions of the aircraft manufacturer.
- Connect negative terminal of aircraft battery.

### 3.8) Test run

Conduct test run. See also chapter 12-20-00 current issue of Maintenance Manual Line for the engine type 912/914 Series.

### 3.9) Summary

These instructions (section 3) have to be conducted in accordance with the deadlines from section 1.5. The execution of the mandatory Service Bulletin must be confirmed in the logbook.

Approval of translation to best knowledge and judgement-in any case the original text in German language and the metric units (SI-system) are authoritative.

### 3.10) Enquiries

Enquiries regarding this Service Bulletin should be sent to the ROTAX® authorized distributor of your area. A list of all distributors is provided on [www.FLYROTAX.com](http://www.FLYROTAX.com).

**NOTE:**

The illustrations in this document show a typical construction. They may not represent full detail or the exact shape of the actual parts but have the same or similar function.

Exploded views are **no technical drawings** and are for reference only. For specific detail, refer to the current documents of the respective engine type.